

EU Type Examination Certificate

No. 0200-NAWI-11532 Revision 1

T7 / NS7 / U8 / E7 / S10 / D10 / S15 / PT30

NON-AUTOMATIC WEIGHING INSTRUMENT

Issued by **FORCE Certification**
EU - Notified Body No. 0200

In accordance with the requirements in Directive 2014/31/EU of the European Parliament and Council.

Issued to **Tscale Electronics Mfg. (Kunshan) Co., Ltd.**
No. 99 Jingwei Road,
Zhoushi, Kunshan, Jiangsu
CHINA

In respect of Non-automatic weighing instrument T7 / NS7 / U8 / E7 / S10 / D10 / S15 / PT30 with variants of modules of load receptors, load cells and peripheral equipment.
Accuracy class III
Maximum capacity, Max: From 1 kg up to 750 000 kg
Verification scale interval: $e = \text{Max} / n$
Maximum number of verification scale intervals: $n \leq 7500$ for single-interval and $n \leq 2 \times 7500$ for multi-range and multi-interval (however, dependent on environment and the composition of the modules).
Variants of modules and conditions for the composition of the modules are set out in the annex.

The conformity with the essential requirements in annex 1 of the Directive is met by the application of the European Standard EN 45501:2015 and of OIML R76:2006.

Note. This certificate is a revised edition which replaces previous revisions.

The principal characteristics and approval conditions are set out in the descriptive annex to this certificate.

The annex comprises 27 pages.

Issued on **2023-10-19**
Valid until **2031-11-02**

FORCE Certification references:

Task no.: 123-31197.90.10 and ID no.: 0200-NAWI-15563-1

Signatory: Jens Hovgård Jensen

FORCE Certification A/S · Park Alle 345 2605 Brøndby Tel+45 43 25 01 77

info@forcecertification.com www.forcecertification.com
forcecertification.com/en/weighing

Descriptive annex

Contents	Page
1. Name and type of instrument and modules	2
2. Description of the construction and function	2
2.1 Construction	2
2.2 Functions	3
3. Technical data	6
3.1 Indicator	6
3.2 Load receptors, load cells, and load receptor supports	7
3.3 Platforms, weigh bridge platforms	7
3.4 Composition of modules	8
3.5 Documents	8
4. Interfaces and peripheral equipment	8
4.1 Interfaces	8
4.2 Peripheral equipment	8
5. Approval conditions	9
5.1 Measurement functions other than non-automatic functions	9
5.2 Counting operation is not approved for NAWI	9
5.3 Compatibility of modules	9
6. Special conditions for verification	9
6.1 Composition of modules	9
7. Securing and location of seals and verification marks	9
7.1 Securing and sealing	9
8. Location of CE mark of conformity and inscriptions	10
8.1 Indicator	10
9. Pictures	11
10. Composition of modules – an example	27

1. Name and type of instrument and modules

The weighing instruments are designated T7 / NS7 / U8 / E7 / S10 / D10 / S15 / PT30. It is a family of electronic non-automatic weighing indicators to be connected to a separate load receptor and peripheral equipment, such as printers or other devices, as appropriate. The instrument is a Class III, self-indicating weighing instrument with single-interval, multi-interval (dual) or multirange (dual), an external AC mains adapter or main power cord, and an internal rechargeable battery (optional).

The indicator name will be followed by a suffix in the form '-nn' indicating the installed software package, which can be one of the following,

- 15 Price computing/Price labelling (PT30 model)
- 40 weighing (10 ID)
- 50 weigh bridge weighing
- 60 multi function
- 90 medical weighing

The model PT30 with the '-15' software installed can act as direct sale to the public under the condition that the display is visible for the customer.

The indicators consist of analogue to digital conversion circuitry, microprocessor control circuitry, power supply, keyboard, non-volatile memory for storage of calibration and setup data, and a weight display contained within a single enclosure.

The modules appear from Sections 3.1, 3.2, and 3.3; the principle of the composition of the modules is set out in Sections 6.1 and 10.

2. Description of the construction and function

2.1 Construction

2.1.1 Indicator

The indicator is specified in Section 3.1.

Enclosures and keyboard

The indicators are housed in an enclosure made of ABS plastic (E7, T7, U8 D10 and PT30 models) or of stainless steel (NS7, S10 and S15 models).

The front panels of the indicator comprise of

- Either a 7" touch-screen LCD display with backlight incorporating appropriate state indicators (models x7-xx and PT-30),
- Or an 8" touch-screen LCD display with backlight incorporating appropriate state indicators (models x8-xx)
- Or a 10.1" touch-screen LCD display with backlight incorporating appropriate state indicators (models x10-xx)
- Or a 15.6" touch-screen LCD display with backlight incorporating appropriate state indicators (models x15-xx)
- The indicators may have in addition to the key-in possibilities on the touch screen, a keyboard containing 4 keys used to enter commands into the weight indicator plus a key for turning the indicator on/off. Each key is identified with a pictograph.

Electronics

The instruments have the following printed circuit boards, a mainboard, a piggy-back for A/D conversion and a separate PCB for interfaces, which together contain all of the instrument circuitry. The metrological circuitries for the weighing indicator models are identical.

All instrument calibration and metrological setup data are contained in non-volatile memory. The indicators are either power supplied by 100-240 VAC or from an input voltage of 12 VDC or for the PT30 model 24 VDC from the external power adapter with input from 100 – 240 VAC 50/60 Hz. The indicator produces a load cell excitation voltage of 5 VDC.

2.1.2 Load receptors, load cells and load receptor supports

Set out in Section 3.2.

2.1.3 Interfaces and peripheral equipment

Set out in Section 4.

2.2 Functions

The weight indicating instruments are microcontroller based electronic weight indicators that require the external connection of strain gauge load cell(s). The weight information appears in the digital display located on the front panel and may be transmitted to peripheral equipment for recording, processing or display.

The primary functions provided are detailed below.

2.2.1 Power-up

On power-up, the indicator will first perform a check of its integrity. After that the indicators will automatically establish the current weight as a new zero reference.

2.2.2 Display test

No display test is performed as it is a graphic display.

2.2.3 Display range

The weight indicators will display weight from $-20d(\text{gross})/-(\text{Max}+20d)$ (tare function) to $\text{Max}+9e$ (gross weight).

2.2.4 Zero-setting

Zero-setting range: $\pm 2\%$ of Max.

Automatic zero-tracking range: $\pm 2\%$ of Max.

Initial zero-setting range: $\leq \pm 10\%$ of Max.

Zero-setting is only possible when the load receptor is not in motion.

2.2.4.1 Semi-automatic zero-setting

Pressing the “ZERO” key causes a new zero reference to be established and ZERO annunciator to turn on, indicating that the display is at the centre of zero.

2.2.4.2 Zero-tracking

The indicators are equipped with a zero-tracking feature, which operates over a range of $\pm 2\%$ of Max and only when the scale is at gross zero and there is no motion in the weight display. The zero-tracking shall be set to 0.5 d per second.

2.2.5 Tare

The instrument models are provided with a semi-automatic subtractive tare.

2.2.5.1 Semi-automatic tare

Pressing the “TARE” key will enter the currently weight value as the new tare weight value, if the tare function is not already active or setup allows multi-tare operation.

The weight display will automatically change to the net weight display mode and turn on the NET annunciator and the tare value will be displayed. This tare value can be cleared by pressing the TARE key when there is no load on the load receptor. This tare entry cannot take place if the load receptor is in motion.

2.2.5.2 Preset tare

The ‘-15’, ‘-40’ and ‘-60’ software package has a preset tare function with possibility for storing 4 different preset tare values in memory.

On models with ‘-40’ and ‘-60’ software package the PT key is used for accessing.

On models with ‘-15’ software package Preset Tare value is input with a long press on Tare key.

2.2.6 Manual check weighing

The indicators can be set to check the actual weight against a high and/or a low limit by the user pressing “Hi-Lo” key and then setting the appropriate parameters. In the xn-60 indicators are additional graphic aids for the operator.

2.2.7 Checkweighing limits Look Up (PLU)

The xn-40 and xn-60 indicators can store up to 99999 high and/or low limits for checkweighing. These are accessed using the PLU keys, the three product category keys and the two arrow keys.

Access to editing them can be obtained using the menu key and selecting products.

2.2.8 Counting

The xn-20 and xn-60 indicators have a counting function. The number of samples on the load receptor can be keyed in using the “SAMPLES” key, or the unit weight of one piece can be keyed in using the “U.W.” key, or it can be recalled from the look-up table of unit weights using the “PRODUCT” key.

Neither the unit weight nor the count shown in counting mode is to be regarded as an approved weighing result.

2.2.9 Piece unit weight Look Up (PLU)

The xn-40 and xn-60 indicators can store up to 99999 unit weight values. These are accessed using the PLU keys, the product category key, and the two arrow keys.

The PT 30 model with ‘-15’ software can store up to 999999 unit price values. These are accessed using the PLU keys.

Access to editing them can be obtained using the menu key and selecting products.

2.2.10 Truck weighing

The xn-50 indicators have special features for facilitating 2-stage weighing of trucks – empty/full or full/empty – keeping track of it based on the registration plate of the truck.

2.2.11 Printing

A printer may be connected to an USB port or to the RS232 interface or is built into the indicator (model E7 and PT30). The weight indicator will transmit the current indication to the printer when the “PRINT” or “SAVE” key is pressed.

The printing will not take place if the load receptor is not stable, if the gross weight is less than zero, or if the weight exceeds Max.

2.2.12 Facilitated weighing operations

The xn-60 indicators have a number of functions facilitating weighing operations. These are,

- | | |
|--------------------|--|
| Class operation | for sorting items into 5 different grades based on weight. |
| Take out operation | for display of removed weight during down weighing and also accumulating the removed weight. |
| Target operation | for comparing the accumulated weight of a number of separate weighings against a target |
| Recipe operation | assisted weighing of components for a recipe. |

2.2.13 Extended resolution ($\times 10$)

The indicators have an extended resolution function. A separate key on the touch screen is used for this and a press on this key will show the weight with $d = 0.1e$ for 5 seconds.

2.2.14 Totalisation

The indicators have a totalisation function, adding actual weight display values to the memory when pressing “Print-SAVE” key, if the equilibrium is stable.

The totalised value is a calculated value and shall be marked as such when printed using the “TOTAL” key.

2.2.15 Operator information messages

The weight indicator has a number of general and diagnostic messages, which are described in detail in the user’s guide.

2.2.16 Software version

The software is separated in a weighing software and an application software.

The software version of the weighing software is shown under system settings in the menu, while the software version of the application soft is displayed in the top line of the T-Touch screen.

The approved software versions are,

Weighing software: S1.02.xx

Printer software: P1.06.xx

Application software version has the format: An.xx.(z)

where

n = 1 for software ‘-50’

n = 2 for software ‘-15’

n = 4 for software ‘-40’

n = 6 for software ‘-60’

n = 9 for software ‘-90’

xx are from 00 to 99, and the optional z is from a to z.

2.2.17 Alibi memory (optional)

The indicators have an optional data storage device (DSD), which can store all the weighing results, when enabled. The alibi memory is organized as a cyclic buffer of alibi records.

2.2.18 Gravity compensation

The indicators have a gravity compensation function making it possible to perform the verification at a place with another gravity constant than the place of use. The function is sealed.

2.2.19 Battery operation

The indicators can optionally be operated from the internal rechargeable battery except S10, D10 and S15.

3. Technical data

The weighing instruments are composed of separate modules, which are set out as follows:

3.1 Indicator

The indicators have the following characteristics:

Type:	T7 / NS7 / U8 / E7 / S10 / D10 / S15 / PT30
Accuracy class:	III
Weighing range:	Single-interval, multi-range (2 ranges) or multi-interval (2 partial intervals)
Maximum capacity (Max):	≤ 750 000 kg
Maximum number of Verification Scale Intervals:	≤ 7500 for single-interval ≤ 2x7500 for multi-range and multi-interval
Maximum tare effect:	-Max
Fractional factor:	$\rho'i = 0.5$
Minimum input voltage per VSI:	0.5 μ V
Excitation voltage:	5 VDC
Circuit for remote sense:	present
Minimum input impedance:	43 ohm
Maximum input impedance:	1600 ohm
Mains power supply:	100-240 VAC 50/60 Hz or 12 VDC or for the PT 30 model 24 VDC using external adapter for / 100-240 VAC, 50/60 Hz 7.4 V battery (optional)
Operational temperature:	-10°C to 40°C
Peripheral interface:	Set out in Section 4

3.1.1 Connecting cable between the indicator and load cell / junction box for load cell(s)

3.1.1.1 4-wire system

Cable between indicator and load cell(s): 4 wires (no sense), shielded
 Maximum length: the certified length of the load cell cable, which shall be connected directly to the indicator.

3.1.1.2 6-wire system

Cable between indicator and load cell(s): 6 wires (sense), shielded.
 Maximum cable length between indicator and junction box (J-box) for load cell(s): 461 m/mm²

3.2 Load receptors, load cells, and load receptor supports

Removable platforms shall be equipped with level indicators.

3.2.1 General acceptance of modules

Any load cell(s) may be used for instruments under this certificate of type approval provided the following conditions are met:

- 1) There is a respective Part / Evaluation / Test Certificate (EN 45501) or an OIML Certificate of Conformity (R60:2000 or R60:2017) issued for the load cell by a Notified Body responsible for type examination under Directive 2014/31/EU.
- 2) The certificate contains the load cell types and the necessary load cell data required for the manufacturer's declaration of compatibility of modules (WELMEC 2:2015), and any particular installation requirements). A load cell marked NH is allowed only if humidity testing to EN 45501 has been conducted on this load cell.
- 3) The compatibility of load cells and indicator is established by the manufacturer by means of the compatibility of modules form, contained in the above WELMEC 2 document, or the like, at the time of EU verification or declaration of EU conformity of type.
- 4) The load transmission must conform to one of the examples shown in the WELMEC 2.4 Guide for load cells.

3.3 Platforms, weigh bridge platforms

Construction in brief	Metal or steel-reinforced concrete construction, surface or pit mounted
Reduction ratio	1
Junction box	Mounted in or on the platform
Load cells	Load cell according to Section 3.2.1
Drawings	Various

3.3.1 Bin, tank, hopper and non-standard systems

Construction in brief	Load cell assemblies each consisting of a load cell stand assembly to support one of the mounting feet bin, tank or hopper
Reduction ratio	1
Junction box	Mounted on dead structure
Load cell	Load cell according to Section 3.2.1
Drawings	Various

3.4 Composition of modules

In case of composition of modules, EN 45501:2015 annex F shall be satisfied.

3.5 Documents

The documents filed at FORCE (reference No. 121-25363) are valid for the weighing instruments described here.

4. Interfaces and peripheral equipment

4.1 Interfaces

The interfaces are characterised “Protective interfaces” according to paragraph 8.4 in the Directive.

4.1.1 Load cell input

A 7-terminal connector for the load cell is positioned on the back of the enclosure.

4.1.2 Load cell input from second platform load receptor (optional)

A 7-terminal connector for connection of the load cell cable from a second platform type load receptor.

4.1.3 RS-232/RS485/RS422 interface

The indicator is equipped with one or two serial interfaces for connection to a computer or to a printer.

4.1.4 USB interface

The indicator is equipped with two USB interfaces for connection to peripheral equipment. The length of the USB cables is specified to be less than 3 meters.

4.1.5 Ethernet interface

The indicators may be equipped with a RJ45 connector for connection of the scale to a Local Area Network.

4.1.6 Wi-Fi interface (optional)

The indicators may be equipped with a Wi-Fi interface.

4.1.7 I/O interface (optional S10/D10/S15)

The indicators may be equipped with a I/O interface.

4.2 Peripheral equipment

Connection between the indicator and peripheral equipment is allowed by screened cable.

The instrument may be connected to any simple peripheral device with a CE mark of conformity.

5. Approval conditions

5.1 Measurement functions other than non-automatic functions

Measurement functions that will enable the use of the instrument as an automatic weighing instrument are not covered by this type approval.

5.2 Counting operation is not approved for NAWI

The count shown as result of the counting function is not covered by this NAWI approval.

5.3 Compatibility of modules

In case of composition of modules, EN 45501:2014 annex F shall be satisfied.

6. Special conditions for verification

6.1 Composition of modules

The environmental conditions should be taken into consideration by the composition of modules for a complete weighing instrument, for example instruments with load receptors placed outdoors and having no special protection against the weather.

The composition of modules shall agree with Section 5.3.

An example of a declaration of conformity document is shown in Section 10.

7. Securing and location of seals and verification marks

7.1 Securing and sealing

Seals shall bear the verification mark of a notified body or alternative mark of the manufacturer according to ANNEX II, module F or D of Directive 2014/31/EU.

7.1.1 Indicator

Access to the configuration and calibration facility requires that the calibration switch is depressed.

On E7 indicators is the calibration switch accessed through a hole in the rear of the enclosure. Sealing the cover plate for this hole with wire and seal prevent access to the calibration jumper and at the same time securing the electronics against dismantling/adjustment.

On NS7, D10, S10, S15 and PT30 indicators is the calibration switch accessed through a hole in the rear or bottom of the enclosure. Access to the calibration jumper and to secure the electronics against dismantling/adjustment - is accomplished with two screws and using wire and seal. The wire is feed through the head of an enclosure assembly screw and a hole in the screw for the hole for the calibration switch.

On T7 and U8 indicators is the calibration switch accessed through a hole in the rear of the enclosure. Sealing the cover plate for this hole with a brittle plastic sticker, while sealing the enclosure - to prevent access to the calibration jumper and to secure the electronics against dismantling/adjustment - is accomplished using wire and seal. The wire is feed through the head of an enclosure assembly screw and a hole next to the screw.

7.1.2 Indicator - load cell connector - load receptor

Securing of the indicator, load receptor and load cell combined is done the following way:

- Sealing of the load cell connector with the indicator by a wire seal.

In special cases where the place of installation makes it impossible to use the above sealing.

- Inserting the serial number of the load receptor as part of the principal inscriptions contained on the indicator identification label.
- The load receptor bears the serial number of the indicator on its data plate.

7.1.3 Peripheral interfaces

All peripheral interfaces are “protective”; they neither allow manipulation with weighing data or legal setup, nor change of the performance of the weighing instrument in any way that would alter the legality of the weighing.

8. Location of CE mark of conformity and inscriptions

8.1 Indicator

8.1.1 CE mark

CE mark and supplementary metrological marking shall be applied to the scale according to article 16 of Directive 2014/31/EU.

8.1.2 Inscriptions

Manufacturer’s trademark and/or name and the type designation is located on the front panel overlay.

In the top line of the display:

- Max, Min, e = , application software version

On a label located on the side of the indicator enclosure:

- Manufacturer’s name and/or trademark
- Postal address of manufacturer
- Type designation
- Accuracy class
- $Max_i, min_i, e_i=$
- Tare
- Temperature range (optional)
- Model no., serial no., electrical data, and other inscriptions

8.1.2.1 Load receptors

On a data plate:

- Manufacturer's name, type, serial number, capacity

In special cases as provided in Section 7.1.2:

- Serial no. of the indicator

9. Pictures



Figure 1 T7 indicator .



Figure 2 NS7 indicator.



Figure 3 U8 indicator.



Figure 4 E7 indicator.



Figure 5 S10 indicator.



Figure 6 D10 indicator.



Figure 7 S15 indicator.



Figure 8 PT30 indicator.

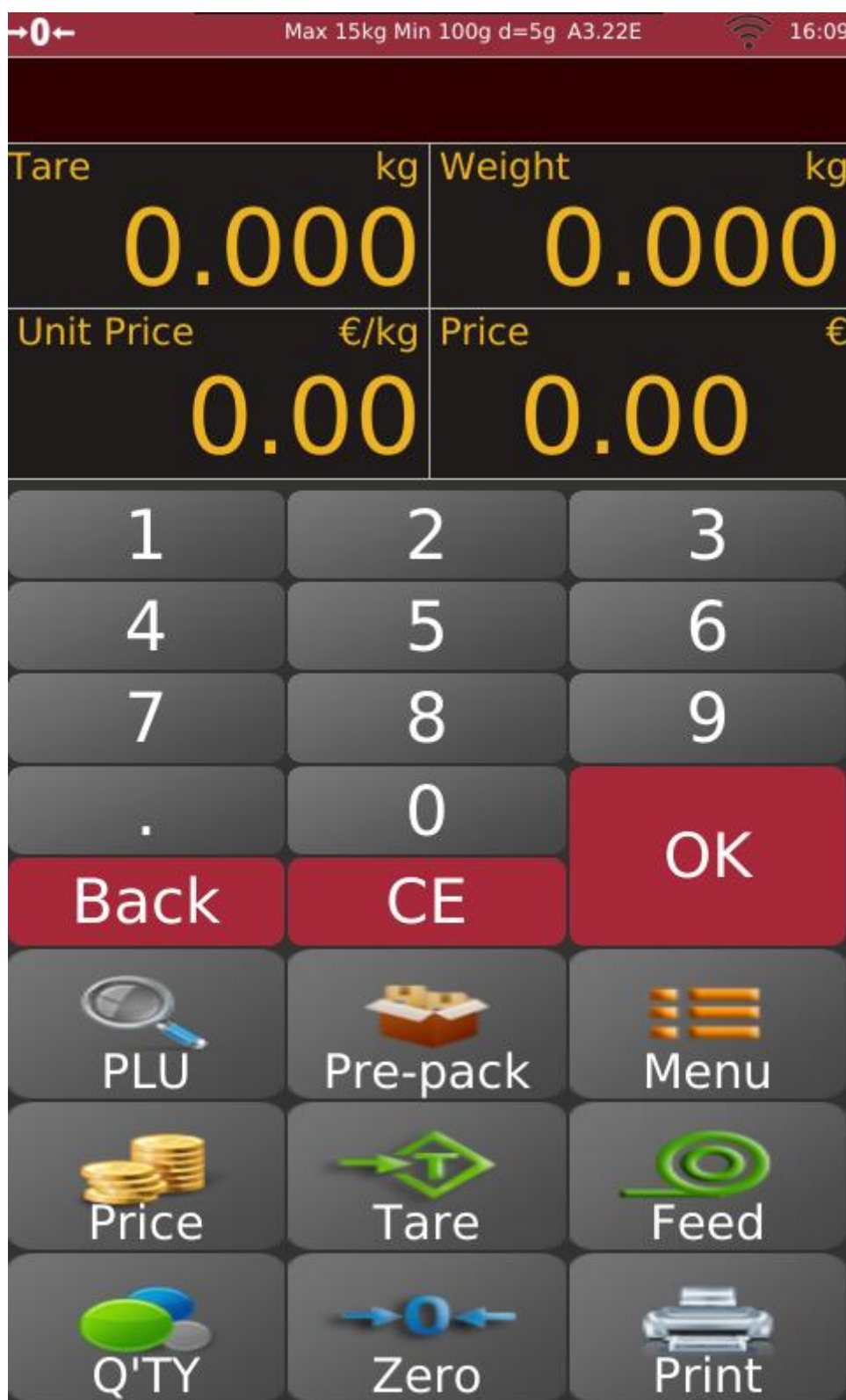

Figure 9 Software package -15 for PT30 model.



Figure 10 Software package -40 for x7 and x8 models.



Figure 11 Software package -40 for x10 and x15 models.

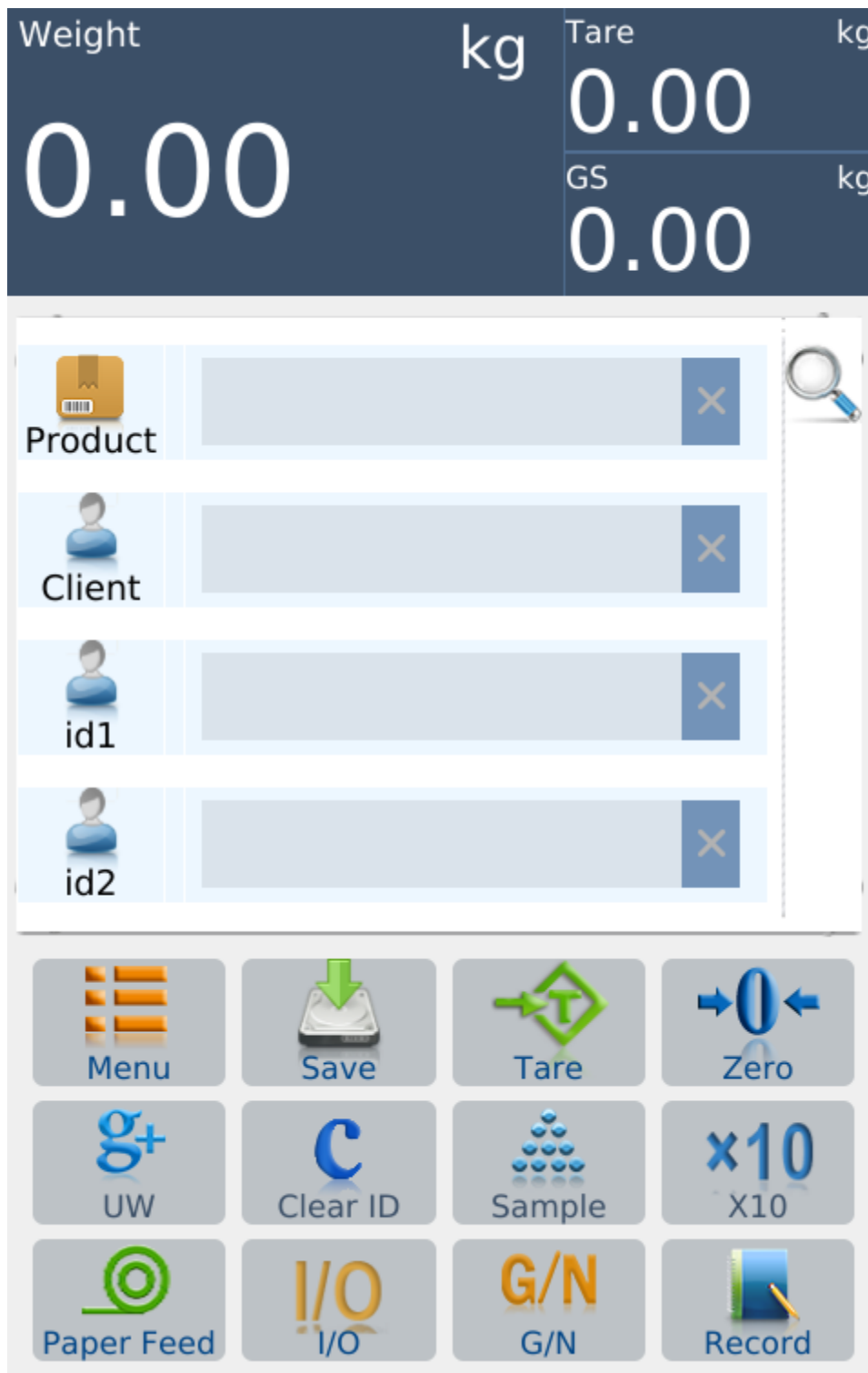

Figure 12 Software package -40 for PT30 model.

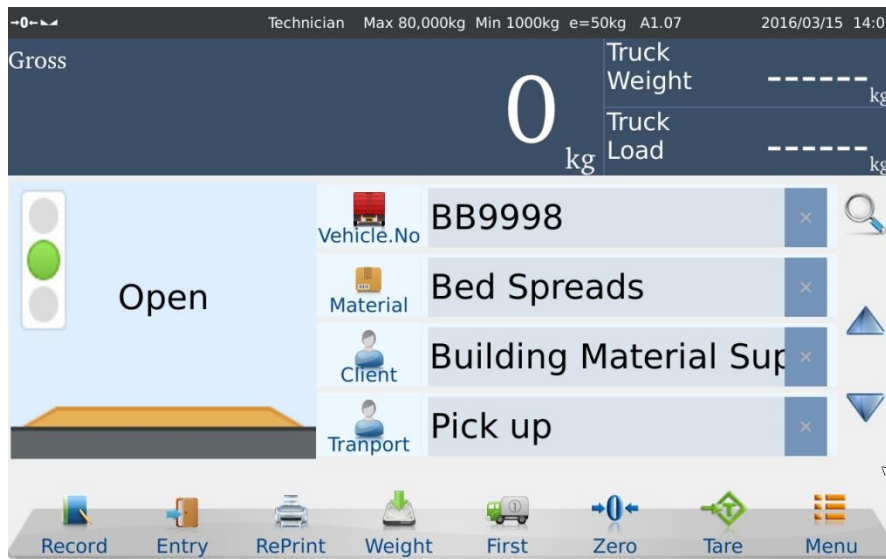

Figure 13 Software package -50.



Figure 14 Software package -60 with check weighing function.



Figure 15 Software package -60 with class weighing function.

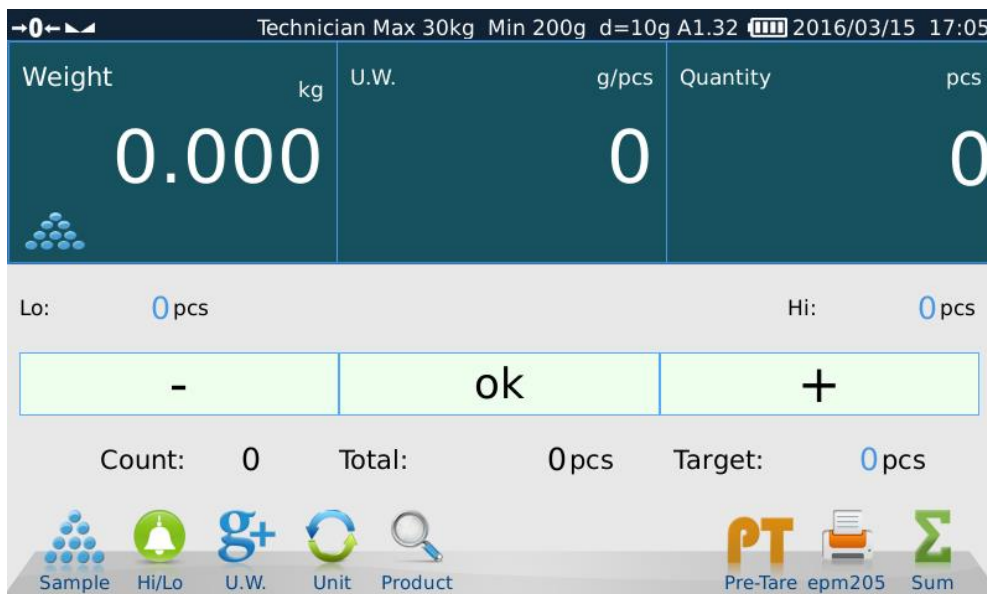

Figure 16 Software package -60 with counting function.

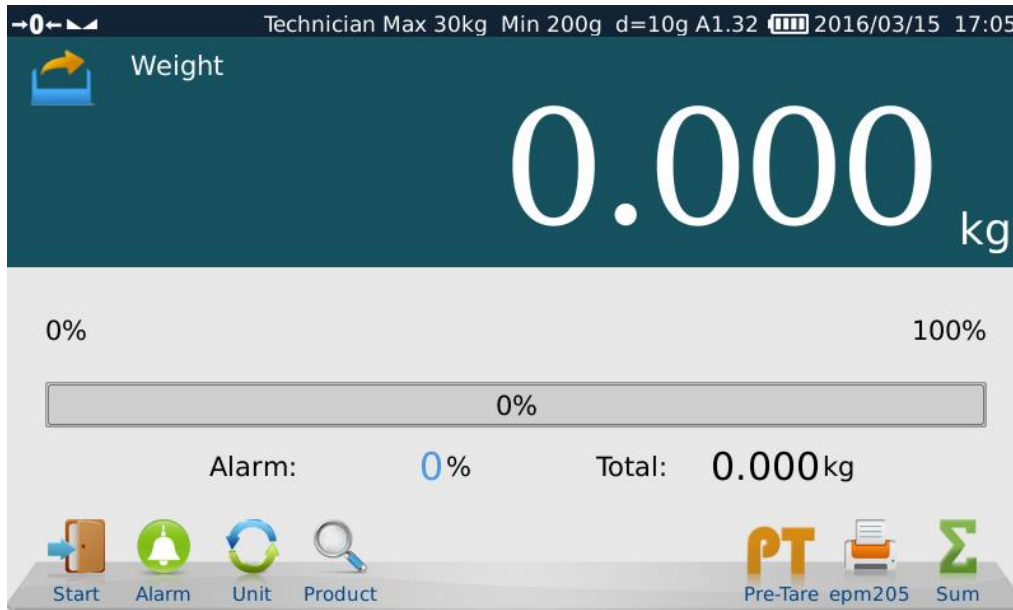

Figure 17 Software package -60 with takeout weighing function.

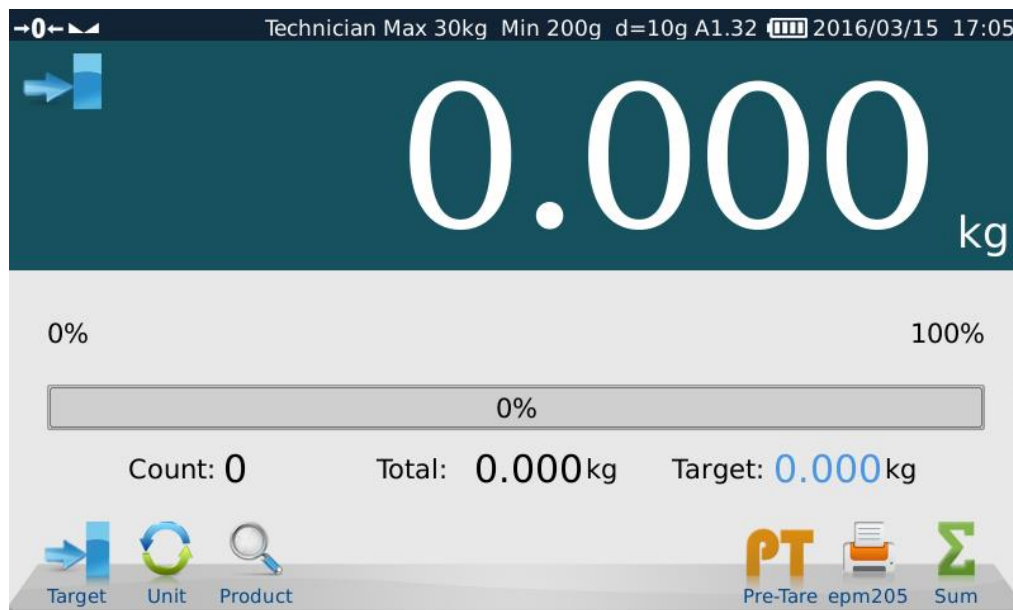
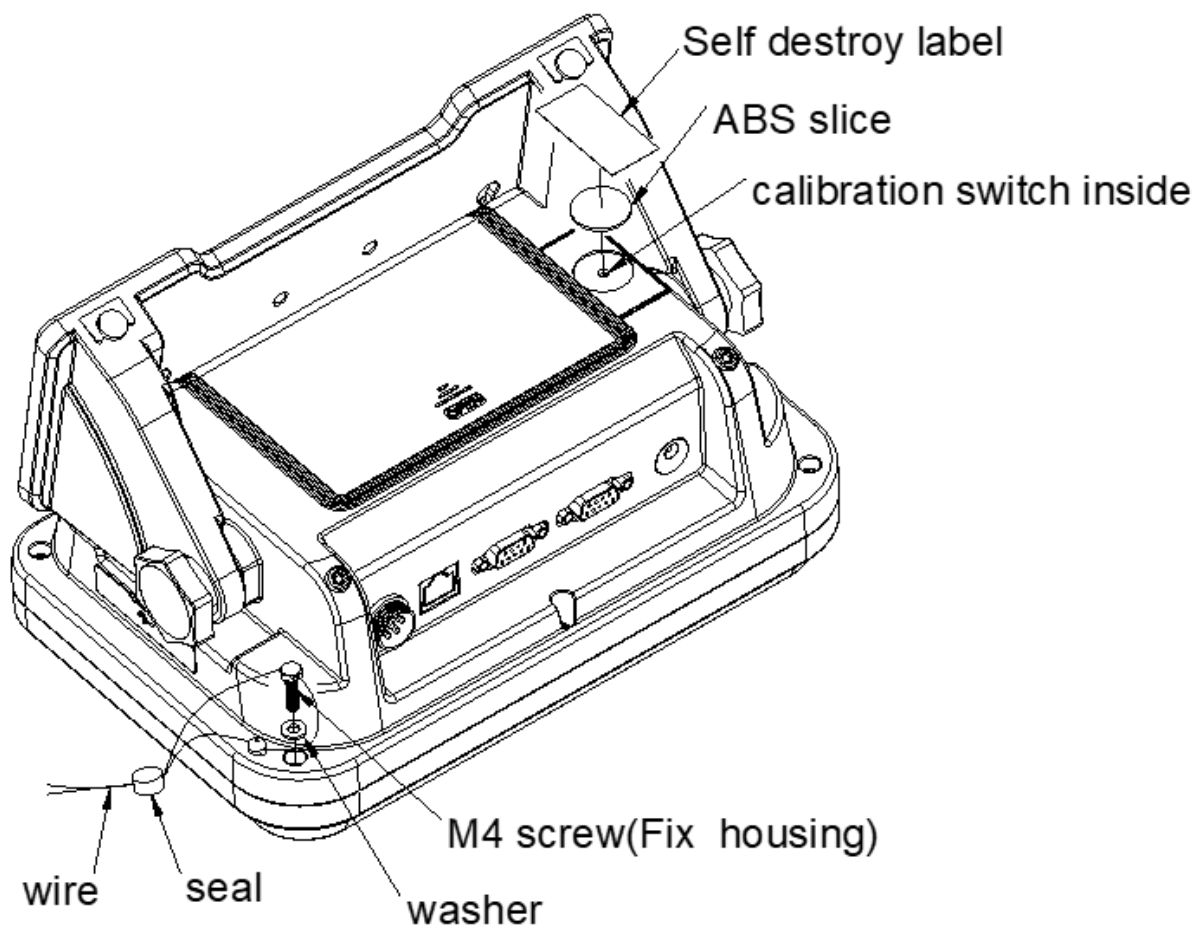

Figure 18 Software package -60 with target weighing function.



Figure 19 Software package -90.



1

Figure 20 Sealing of T7 indicator.

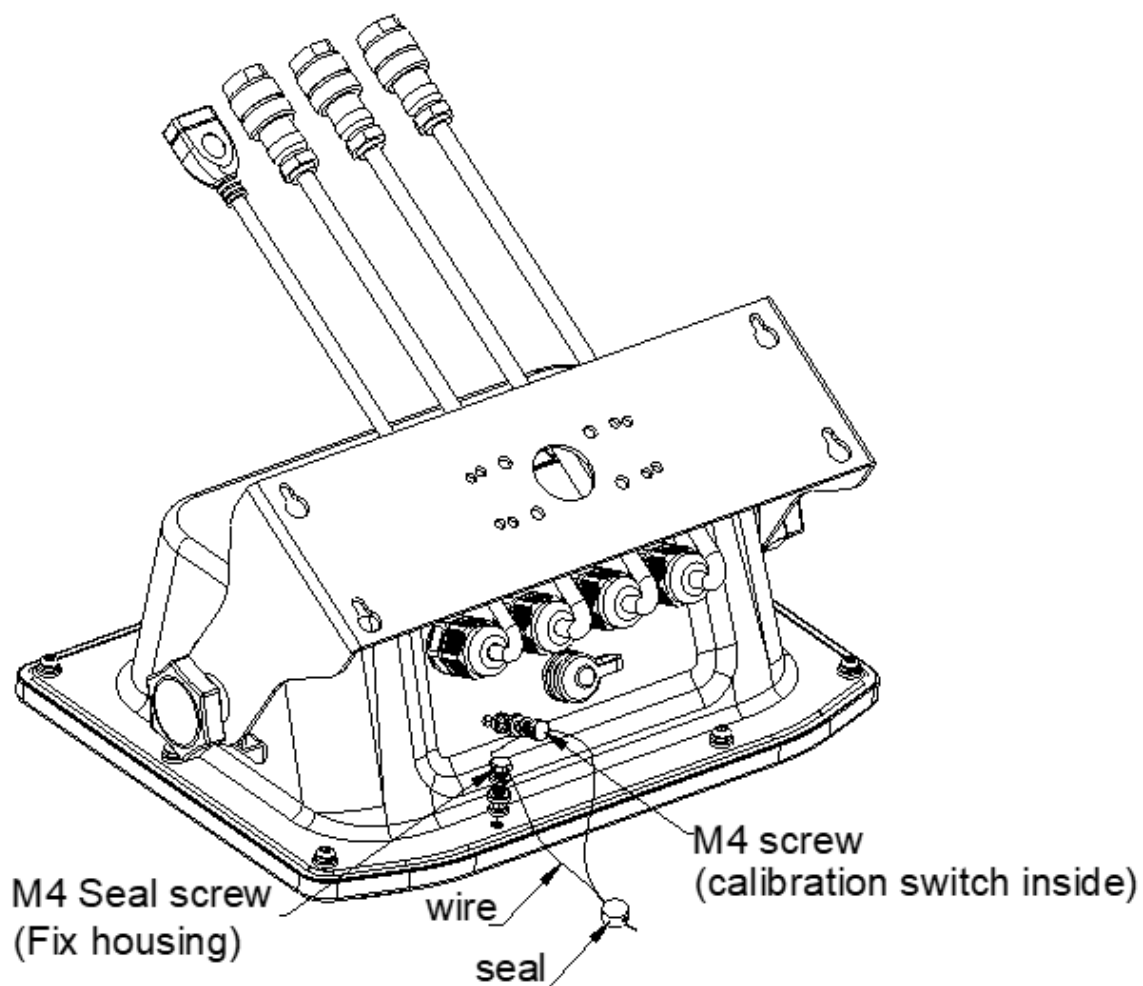

Figure 21 Sealing of NS7 indicator.

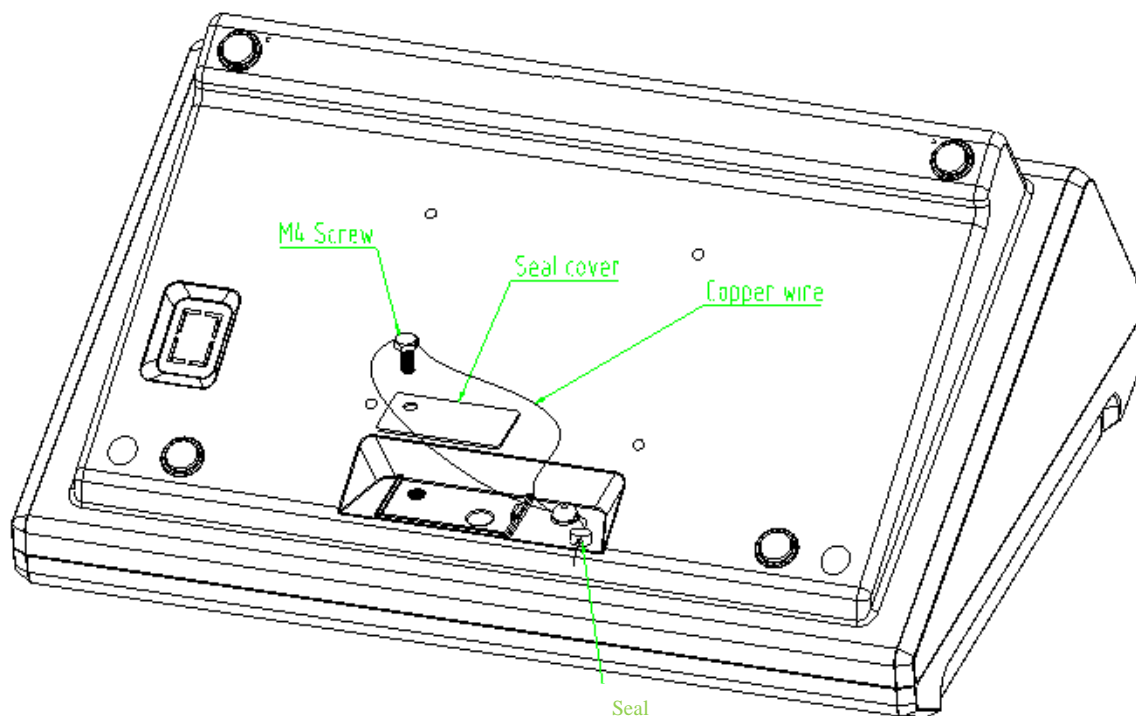

Figure 22 Sealing of E7 indicator.

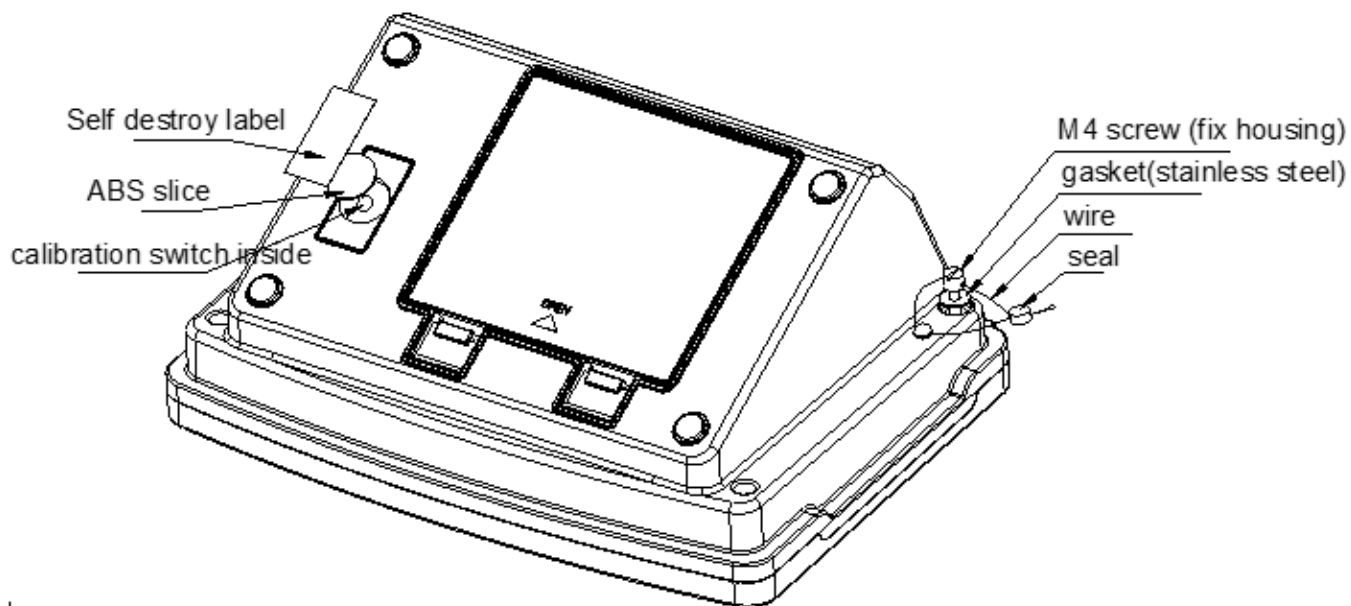

Figure 23 Sealing of U8 indicators.

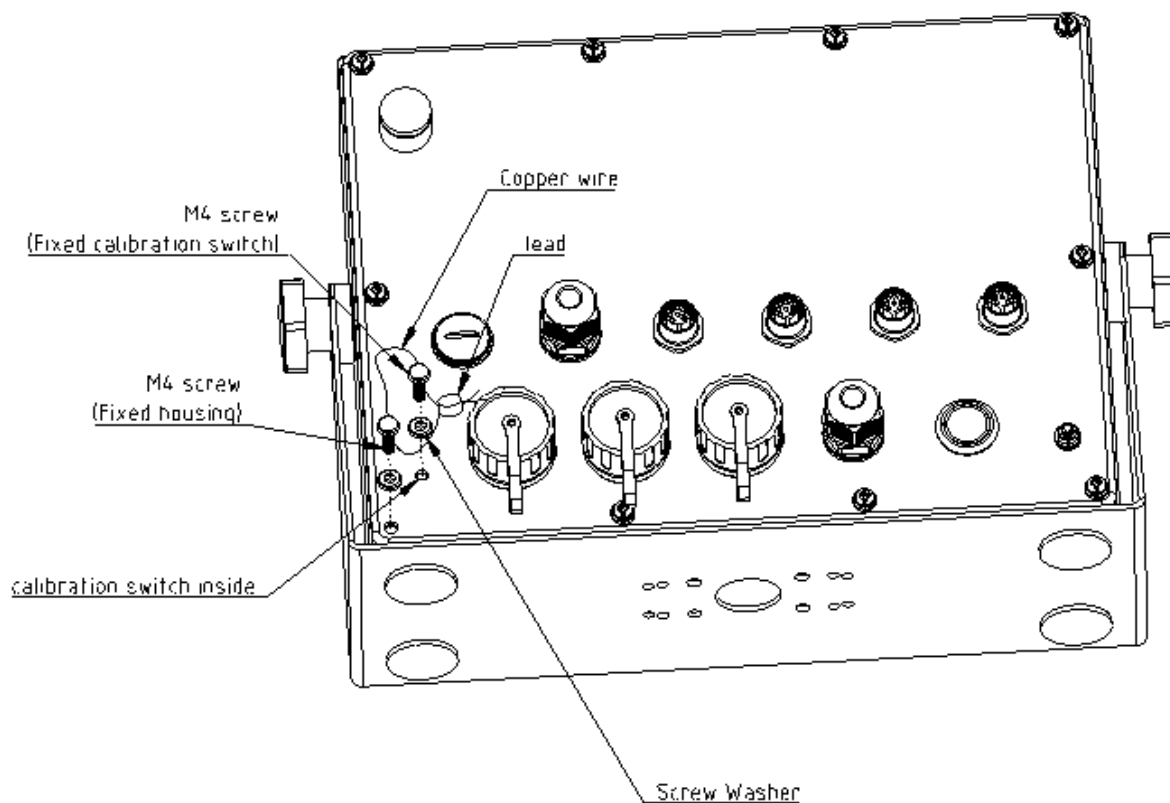

Figure 24 Sealing of S10 indicator.

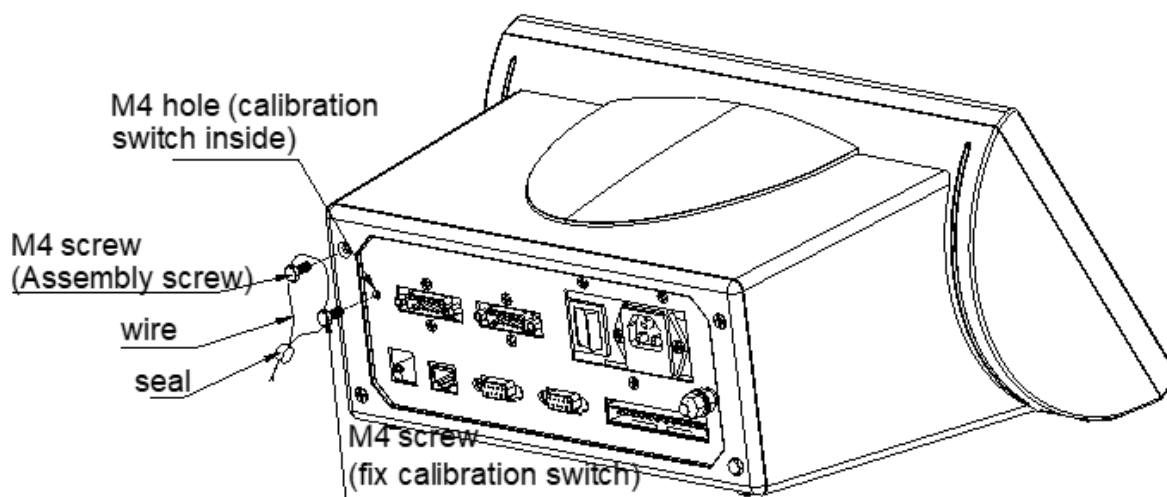

Figure 25 Sealing of D10 indicator.

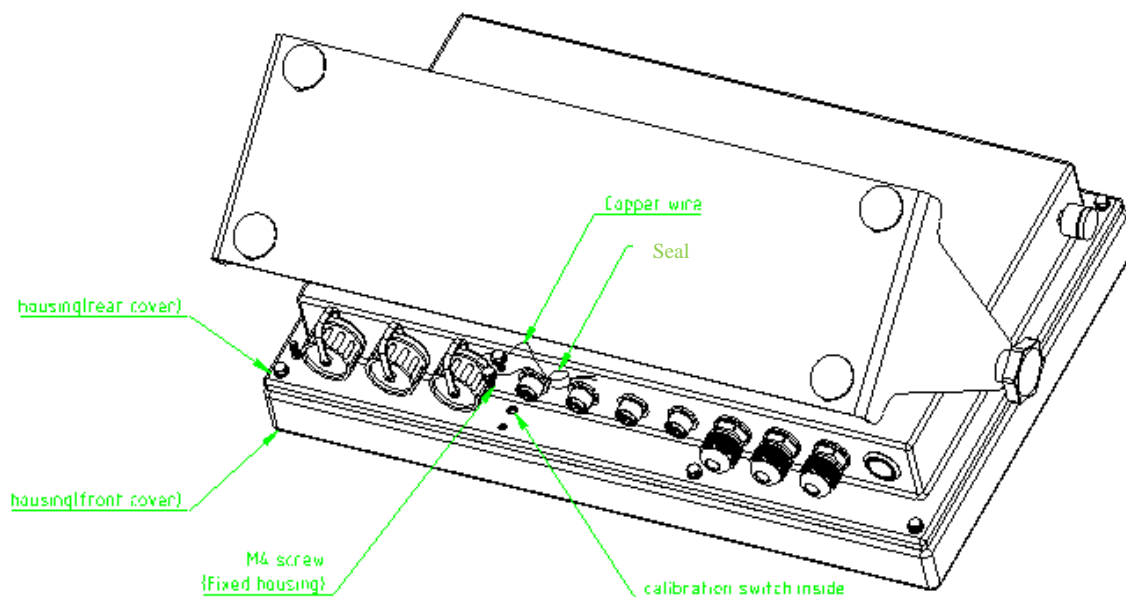
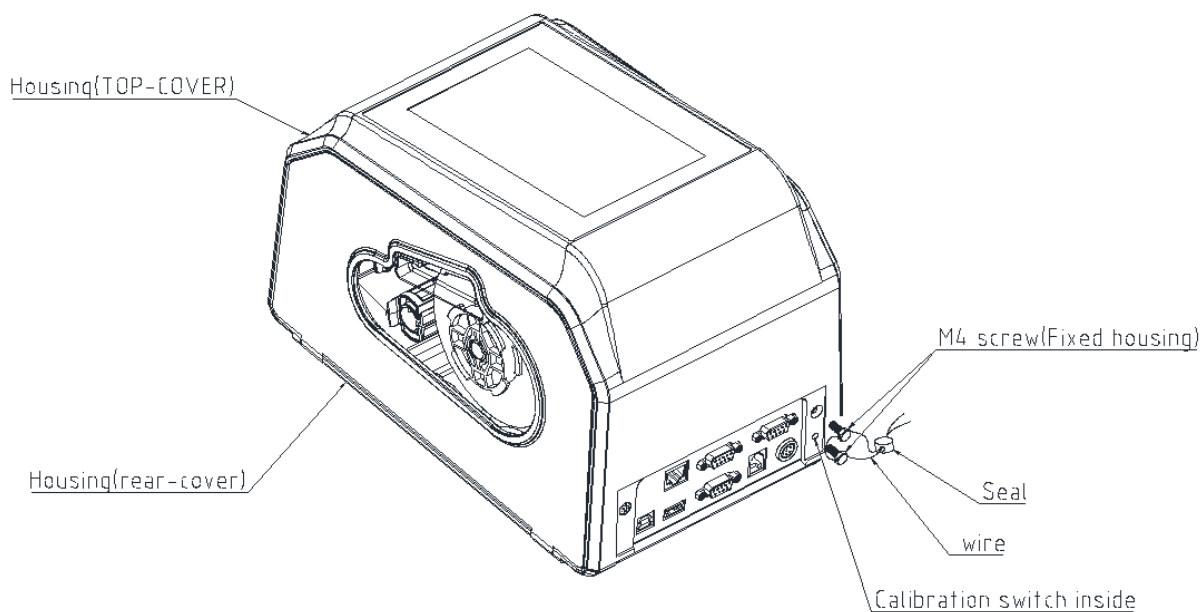

Figure 26 Sealing of S15 indicator.



PT30-seal-drawing

Figure 27 Sealing of PT30 indicator.

10. Composition of modules – an example

COMPATIBILITY OF MODULES

Ref.: WELMEC 2

Non-Automatic Weighing Instrument, single-interval.

Certificate of EU Type Examination N°:

TEC: 0200-NAWI-11532

INDICATOR

A/D (Module 1)

Type: U8
 Accuracy class according to EN 45501 and OIML R76: III
 Maximum number of verification scale intervals (n_{max}): 7500
 Fraction of maximum permissible error (mpe): 0,5
 Load cell excitation voltage: 5 [Vdc]
 Minimum input-voltage per verification scale interval: ΔU_{min} [µV] 0,5
 Minimum load cell impedance: R_{Lmin} [Ω] 43
 Coefficient of temperature of the span error: E_s [% / 25°C]
 Coefficient of resistance for the wires in the J-box cable: S_x [% / Ω]
 Specific J-box cable-Length to the junction box for load cells: $(L/A)_{max}$ [m / mm²] 461
 Load cell interface: 6-wire (remote sense)
 Additive tare, if available: T^+ [% of Max] 0
 Initial zero setting range: I_{ZSR} [% of Max] -10 / 10
 Temperature range: T_{min} / T_{max} [°C] -10 / 40
 Test report (TR), Test Certificate (TC) or OIML Certificate of Conformity: TC8012

LOAD RECEPTOR

(Module 2)

Construction: Platform

Type: Platform
 Fraction of mpe: p2 0,5
 Number of load cells: N 1
 Reduction ratio of the load transmitting device: R=FM / FL 1
 Dead load of load receptor: DL [% of Max] 10
 Non uniform distribution of the load: NUD [% of Max] 0
 Correction factor: $Q = 1 + (DL + T^+ + I_{ZSR} + NUD) / 100$ 1,2
 (NUD = 0 is acceptable)

LOAD CELL

ANALOG (Module 3)

Type: L6D
 Accuracy class according to OIML R60: C
 Maximum number of load cell intervals: nLC 3000
 Fraction of mpe: p3 0,7
 Rated output (sensitivity): C [mV / V] 2
 Input resistance of single load cell: RLC [Ω] 410
 Minimum load cell verification interval: $v_{min\%}$ [% of E_{max}] 0,01
 Rated capacity: E_{max} [kg] 20
 Minimum dead load, relative: $(E_{min} / E_{max}) * 100$ [%] 0
 Temperature range: T_{min} / T_{max} [°C] -10 / 40
 Test report (TR) or Test Certificate (TC/OIML) as appropriate: TC8012

COMPLETE WEIGHING INSTRUMENT

Single-interval

Manufacturer: Tscale Electronics

Accuracy class according to EN 45501 and OIML R76: III

Fractions: $p_i = p_1^2 + p_2^2 + p_3^2$

Maximum capacity: Max [kg] 15

Number of verification scale intervals: n 3000

Verification scale interval: e [kg] 0,005

Utilisation ratio of the load cell: $\alpha = (Max / E_{max}) * (R / N)$ 0,75

Input voltage (from the load cells): $\Delta_u = C * U_{exc} * \alpha * 1000 / n$ [µV/e] 2,50

Cross-section of each wire in the J-box cable: A [mm²] 0,22

J-box cable-Length: L [m] 10

Temperature range to be marked on the instrument: Not required

Peripheral Equipment subject to legal control: T_{min} / T_{max} [°C]

Acceptance criteria for compatibility		Passed, provided no result below is < 0	
Classwl	<= Classind & ClassLC (WELMEC 2: 1)	Classwl	PASSED
pi	<= 1 (R76: 3.5.4.1)	1 - pi	0,0
n	<= n_{max} for the class (R76: 3.2)	n_{max} for the class - n	7000
n	<= n_{ind} (WELMEC 2: 4)	n_{ind} - n	4500
n	<= nLC (R76: 4.12.2)	nLC - n	0
E_{min}	<= $DL * R / N$ (WELMEC 2: 6d)	$(DL * R / N) - E_{min}$	1,5
$v_{min} * \sqrt{N} / R$	<= e (R76: 4.12.3)	$e - (v_{min} * \sqrt{N} / R)$	0,003
or (if v_{min} is not given)		Alternative solutions: ↑ ↓	
$(E_{max} / nLC) * (\sqrt{N} / R)$	<= e (WELMEC 2: 7)	$e - ((E_{max} / nLC) * (\sqrt{N} / R))$	2,00
ΔU_{min}	<= Δu (WELMEC 2: 8)	$\Delta u - \Delta U_{min}$	2,00
R_{Lmin}	<= RLC / N (WELMEC 2: 9)	$(RLC / N) - R_{Lmin}$	367
L / A	<= $(L / A)_{max}^{wl}$ (WELMEC 2: 10)	$(L / A)_{max}^{wl} - (L / A)$	416
T _{range}	<= $T_{max} - T_{min}$ (R76: 3.9.2.2)	$(T_{max} - T_{min}) - T_{range}$	20
$Q * Max * R / N$	<= E_{max} (R76: 4.12.1)	$E_{max} - (Q * Max * R / N)$	2,0

Signature and date:

Conclusion PASSED

This is an authentic document made from the program:
"Compatibility of NAWI-modules version 3.2".